

„Schule-Wirken-Prägung“ is a project of the **Community of Ybbsitz** and the **Community of Brtnice**

and it is funded in the frame of the project FMP/KPF AT-CZ 2014-2020 by European funds for regional development, program „INTERREG V-A Austria - Czech Republic“, and co-financed by NÖ.Regional.GmbH.

INTERNATIONALES

Schmiedefest

FERRACULUM

Ybbsitz, 15., 16. and 17. June²⁰¹⁸

Contact & information
Community of Ybbsitz

Markt 1
AT-3341 Ybbsitz

Project advisors

Mr. Thomas Hochstädt (for EN)

thomas.hochstaedt@gmx.at,
+43 7443 86366, +43 664 4603931

Herr Uwe Plank (für DE)

plank@ybbsitz.gv.at, +43 7443/86601-23

Pan Petr Soudek (pro CZ)

soudekpet@gmail.com , +420 777 170 399

ybbsitz
Schmiedezentrum

noe  regional

ybbsitz
Schmiedezentrum

**SCHULE
WIRKEN
PRÄGUNG**

in memoriam
Prof. Alfred Habermann

Foto: B. Sonnleitner

Epitaph

Monument in memoriam
Professor Alfred Habermann

Dear blacksmith,
dear metal designer,
student, admirer or friend of
professor Alfred Habermann!

We would like to invite you to forge an element for a memorial (Epitaph). You should have an inner reflection and set a materialized expression of your spiritual commemoration to the grand master blacksmith.

Your element will be part of a collective sculpture for dignified remembrance on Alfred Habermann's 10th anniversary of death.

The Elements for the collective sculpture will be collected and presented at FERRACULUM in Ybbsitz in June 2018.

If you would like to give your contribution, then we kindly ask you to submit your element in Haus Ferrum at your arrival to the Ferraculum in Ybbsitz.

You also have the chance to produce your element in one of the forges of Ybbsitz.



EUROPEAN UNION

Interreg 
Austria-Czech Republic
European Regional Development Fund

Collective-Epitaph with individual elements

Epitaph

Monument in memoriam
Professor Alfred Habermann

Individual contribution

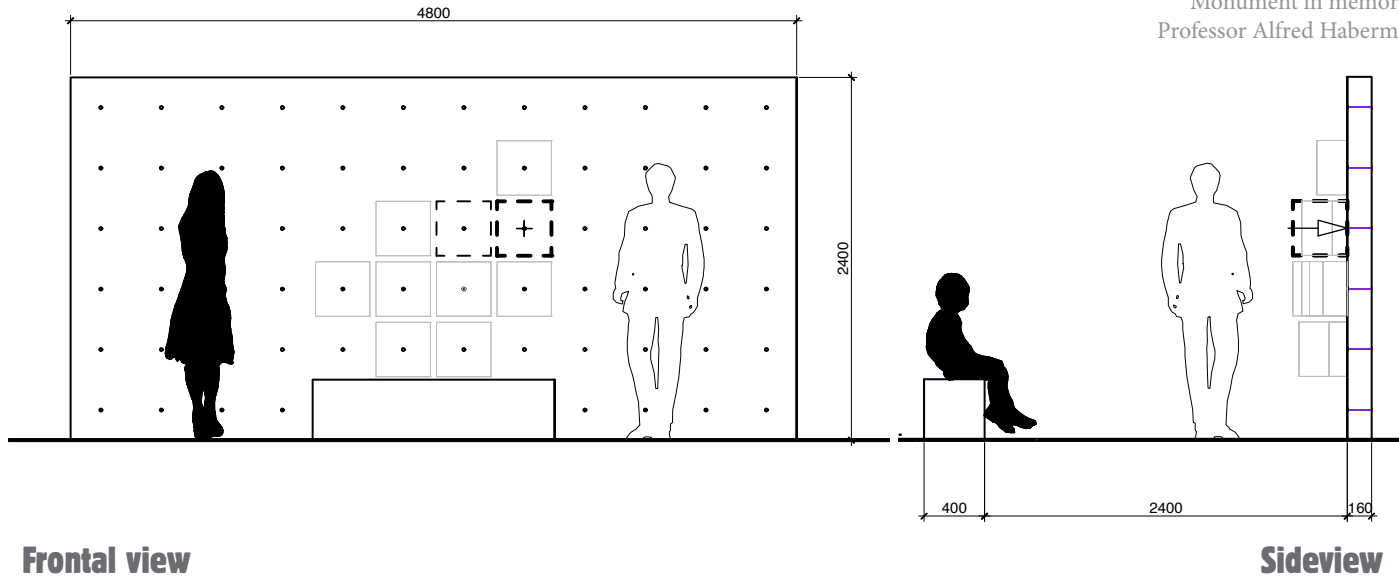

Frontal view

Sideview

Ground plan

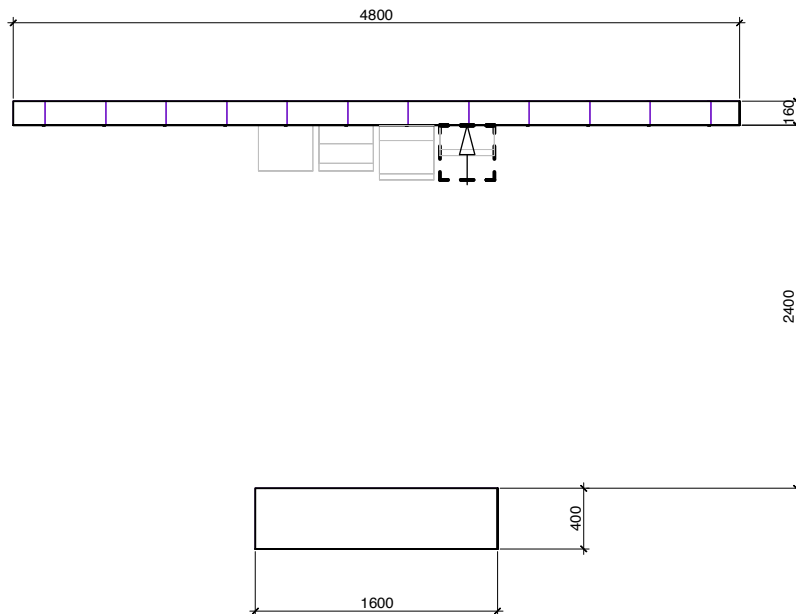

Technical Details:

Basic material:

130 x 60 x 30mm industrial steel

Maximum size of final object:

350 x 350 x 350mm

We have cardboard boxes as transport help and to define this maximum size of object.

Fixing:

There is meant to be a hole of 21mm inner diameter for each individual object in the surface of the framing wall. The mode of fixing depends on every contributor him or herself.

Surface treatment of the finished element:

natural, brushed
(no oil, no wax)

Basic material

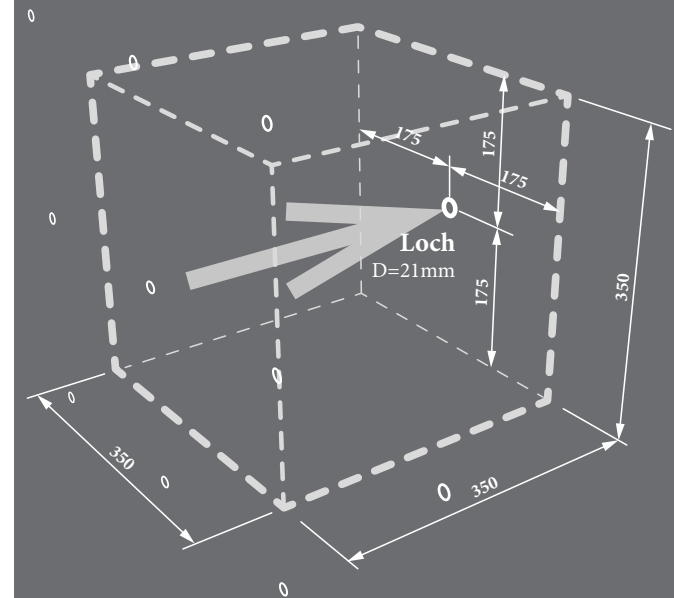
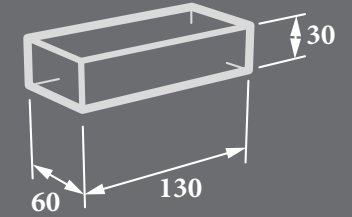

**Imaginary spatial limits
for each individual contribution**

Epitaph

Monument in memoriam
Professor Alfred Habermann

**SCHULE
WIRKEN
PRÄGUNG**

in memoriam
Prof. Alfred Habermann

Foto: B. Sonnleitner

Dear contributor to the collective monument
for the remembrance of professor Alfred
Habermann!

Please give following data and
attach this sheet to your opera at contribution:

INTERNATIONALES

Schmiedefest

FERRACULUM

Ybbsitz, am 15., 16. und 17. Juni²⁰¹⁸

Title of opera (individual element)

Maker (Name SURNAME)

Origin of maker (Place, Country)

Year of birth (19xx)